

**PRESS DIE STANDARD  
COMPONENTS**

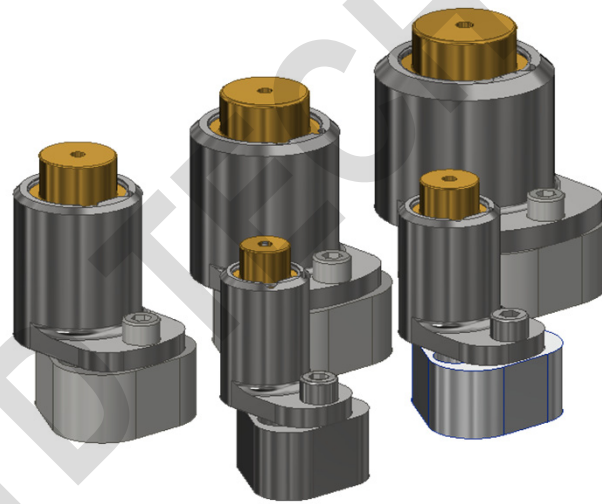

*YouTube / ATD TECH*

**ATD DISK STRIPPER**



**VOL. B1-ADS-EN-R4**

Distributor

**PATENTED**



**B**

## **FEATURES**

- The ADS is an integrated disc spring stripping unit compatible with standard retainers from various series and manufacturers (e.g., Dayton, Misumi) in thicknesses of 25 mm, 30 mm, and 41 mm.  
Available in multiple standard sizes based on punch blank diameters (10 mm, 13 mm, 16 mm, 20 mm, 25 mm).  
The stripper is easily replaceable and can be mounted onto the retainer without additional machining.

## **NOTICE**

- Do not exceed the standard stroke of the copper stripper, as it may lead to deformation.
- Disc springs are preassembled in a fix, non-removable structure to preserve the optimal stacking configuration

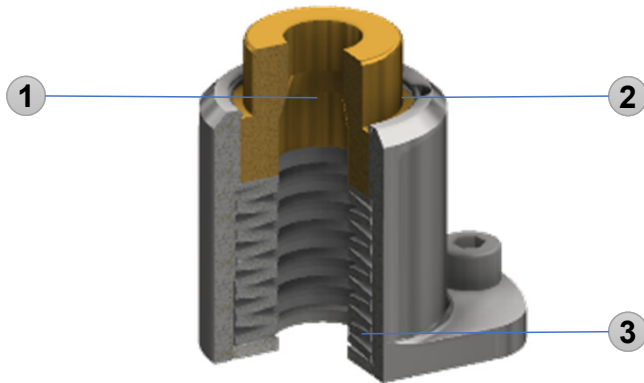

**PATENTED**

No.	Part	Spec.
1	Stripper	CAC304 *SM45C
2	Retaining Ring	
3	Power Unit	
-	Spring	Schonorr
-	Wrench Bolt	M8x25
-	Disk Washer	M8

- Disk springs were assembled non-removable structure to maintain the optimum disc spring stacking structure.

\* MoS2 coated Steel stripper is option

\*L : ◎ / long stroke type

Series	Retainer Thickness			Stripping Force kN (kgf)70	Punch Length			
	25mm	30mm	41mm (Ball lock)		70	80	90	100
ADS-10S	●			1.5 (150)	●			
ADS-10 (L:◎)	●			4.4 (455)		●	●◎	●◎
ADS-13S	●			2.0 (200)	●			
ADS-13 (L:◎)	●			4.7 (480)		●	●◎	●◎
ADS-16S	●			1.9 (190)	●			
ADS-16	●			5.4 (550)			●	●
ADS-20	●			6 (620)			●	●
ADS-25	●			9.7 (990)			●	●
ADS-10M (L:◎)		●		4.4 (455)		●	●◎	●◎
ADS-13M (L:◎)		●		4.7 (480)		●	●◎	●◎
ADS-16M (L:◎)		●		5.4 (550)		●	●◎	●◎
ADS-20M (L:◎)		●		6 (620)		●	●◎	●◎
ADS-25M (L:◎)		●		9.7 (990)		●	●◎	●◎
ADS-10B			●	4.4 (455)			●	●
ADS-13B			●	4.7 (480)			●	●
ADS-16B			●	5.4 (550)			●	●
ADS-20B			●	6 (620)			●	●
ADS-25B			●	9.7 (990)			●	●

- **Note:** Due to the characteristics of the disc spring stacking structure, the maximum stripping force may vary by approximately 7%

**ADS, ADS-S, ADS-L, ADS-B**

(①, ②, ③)

**PATENTED**

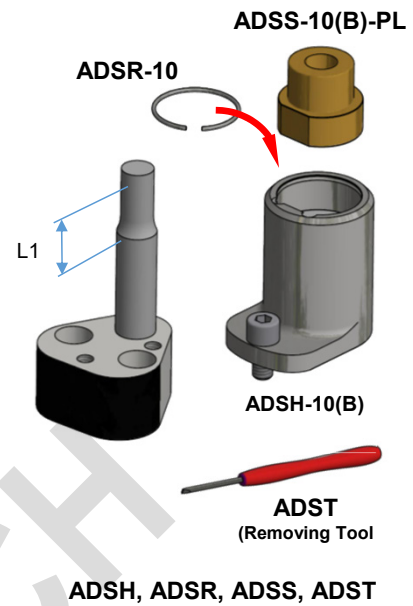
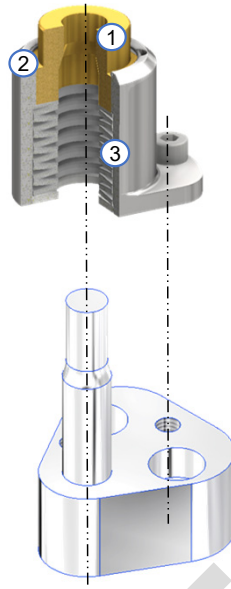
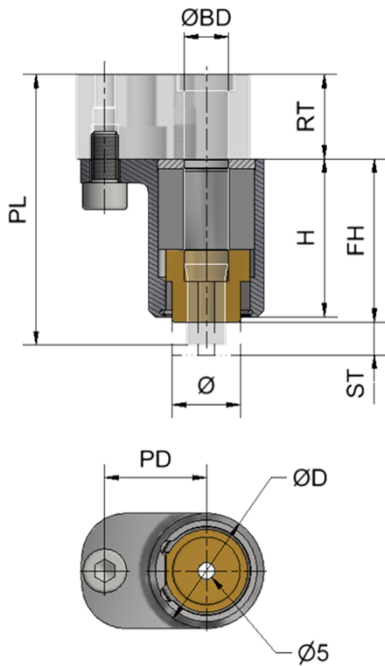

- The stripper has  $\Phi 5$ mm hole

- When ordering with punch and retainer, Delivery with assembled

Series	BD	D	PD	H	* Retainer Thickness(RT)		Punch Length PL / Final Height FH				ST.	* Max. Force								
					25mm	41mm	70mm	80mm	90mm	100mm			mm	kN (kg.)						
ADS-10S	10	30	26.9	37	39.3	41mm	70mm	80mm	90mm	100mm	7.7	1.5 (150)								
ADS-10(B)				46.6									X	X	X					
ADS-10L				55									X	48.2	58.2	68.2	8.3	4.4 (455)		
ADS-13S	13	34	30	37	39.3	41mm	70mm	80mm	90mm	100mm	7.7	2.0 (200)								
ADS-13(B)				46.6									X	X	48.2	58.2	8.3			
ADS-13L				55									X	48.2	58.2	68.2	8.3	4.7 (480)		
ADS-16S	16	43	31.8	37	39.3	41mm	70mm	80mm	90mm	100mm	7.7	1.9 (190)								
ADS-16				54									X	X	56	66	10.5	5.4 (550)		
ADS-16B				45.7									X	X	48.2	58.2	8.3			
ADS-20	20	50	33.5	54.4	39.3	41mm	70mm	80mm	90mm	100mm	7.7	1.9 (190)								
ADS-20B				47									X	X	50	60	7	6 (620)		
ADS-25				25									60	40.6	54.5	39.3	41mm		70mm	80mm
ADS-25B	46	X	X		50	60	7	6 (620)												
						39.3	41mm		70mm	80mm	90mm	100mm			7.7			1.9 (190)		
					39.3			41mm					70mm	80mm		90mm	100mm		7.7	1.9 (190)
						39.3	41mm		70mm	80mm	90mm	100mm			7.7			1.9 (190)		
					39.3			41mm					70mm	80mm		90mm	100mm		7.7	1.9 (190)
						39.3	41mm		70mm	80mm	90mm	100mm			7.7			1.9 (190)		
					39.3			41mm					70mm	80mm		90mm	100mm		7.7	1.9 (190)
						39.3	41mm		70mm	80mm	90mm	100mm			7.7			1.9 (190)		
					39.3			41mm					70mm	80mm		90mm	100mm		7.7	1.9 (190)
						39.3	41mm		70mm	80mm	90mm	100mm			7.7			1.9 (190)		
					39.3			41mm					70mm	80mm		90mm	100mm		7.7	1.9 (190)
						39.3	41mm		70mm	80mm	90mm	100mm			7.7			1.9 (190)		
					39.3			41mm					70mm	80mm		90mm	100mm		7.7	1.9 (190)
						39.3	41mm		70mm	80mm	90mm	100mm			7.7			1.9 (190)		
					39.3			41mm					70mm	80mm		90mm	100mm		7.7	1.9 (190)
						39.3	41mm		70mm	80mm	90mm	100mm			7.7			1.9 (190)		
					39.3			41mm					70mm	80mm		90mm	100mm		7.7	1.9 (190)
						39.3	41mm		70mm	80mm	90mm	100mm			7.7			1.9 (190)		
					39.3			41mm					70mm	80mm		90mm	100mm		7.7	1.9 (190)
						39.3	41mm		70mm	80mm	90mm	100mm			7.7			1.9 (190)		
					39.3			41mm					70mm	80mm		90mm	100mm		7.7	1.9 (190)
						39.3	41mm		70mm	80mm	90mm	100mm			7.7			1.9 (190)		
					39.3			41mm					70mm	80mm		90mm	100mm		7.7	1.9 (190)
						39.3	41mm		70mm	80mm	90mm	100mm			7.7			1.9 (190)		
					39.3			41mm					70mm	80mm		90mm	100mm		7.7	1.9 (190)
						39.3	41mm		70mm	80mm	90mm	100mm			7.7			1.9 (190)		
					39.3			41mm					70mm	80mm		90mm	100mm		7.7	1.9 (190)
						39.3	41mm		70mm	80mm	90mm	100mm			7.7			1.9 (190)		
					39.3			41mm					70mm	80mm		90mm	100mm		7.7	1.9 (190)
						39.3	41mm		70mm	80mm	90mm	100mm			7.7			1.9 (190)		
					39.3			41mm					70mm	80mm		90mm	100mm		7.7	1.9 (190)
						39.3	41mm		70mm	80mm	90mm	100mm			7.7			1.9 (190)		
					39.3			41mm					70mm	80mm		90mm	100mm		7.7	1.9 (190)
						39.3	41mm		70mm	80mm	90mm	100mm			7.7			1.9 (190)		
					39.3			41mm					70mm	80mm		90mm	100mm		7.7	1.9 (190)
						39.3	41mm		70mm	80mm	90mm	100mm			7.7			1.9 (190)		
					39.3			41mm					70mm	80mm		90mm	100mm		7.7	1.9 (190)
						39.3	41mm		70mm	80mm	90mm	100mm			7.7			1.9 (190)		
					39.3			41mm					70mm	80mm		90mm	100mm		7.7	1.9 (190)
						39.3	41mm		70mm	80mm	90mm	100mm			7.7			1.9 (190)		
					39.3			41mm					70mm	80mm		90mm	100mm		7.7	1.9 (190)
						39.3	41mm		70mm	80mm	90mm	100mm			7.7			1.9 (190)		
					39.3			41mm					70mm	80mm		90mm	100mm		7.7	1.9 (190)
						39.3	41mm		70mm	80mm	90mm	100mm			7.7			1.9 (190)		
					39.3			41mm					70mm	80mm		90mm	100mm		7.7	1.9 (190)
						39.3	41mm		70mm	80mm	90mm	100mm			7.7			1.9 (190)		
					39.3			41mm					70mm	80mm		90mm	100mm		7.7	1.9 (190)
						39.3	41mm		70mm	80mm	90mm	100mm			7.7			1.9 (190)		
					39.3			41mm					70mm	80mm		90mm	100mm		7.7	1.9 (190)
						39.3	41mm		70mm	80mm	90mm	100mm			7.7			1.9 (190)		
					39.3			41mm					70mm	80mm		90mm	100mm		7.7	1.9 (190)
						39.3	41mm		70mm	80mm	90mm	100mm								

B2

**ADS-M/ML** (①, ②, ③)

\* ML : Long stroke

**PATENTED**

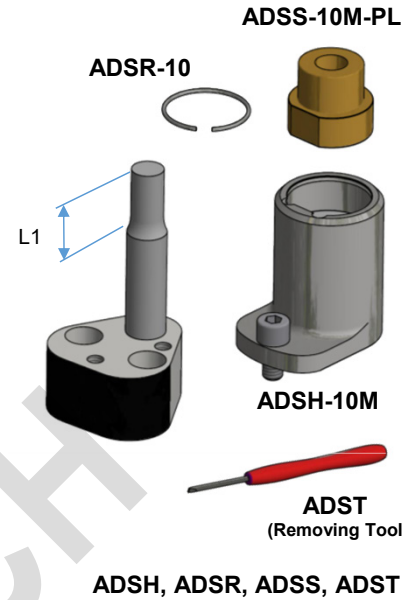
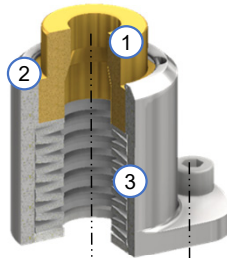
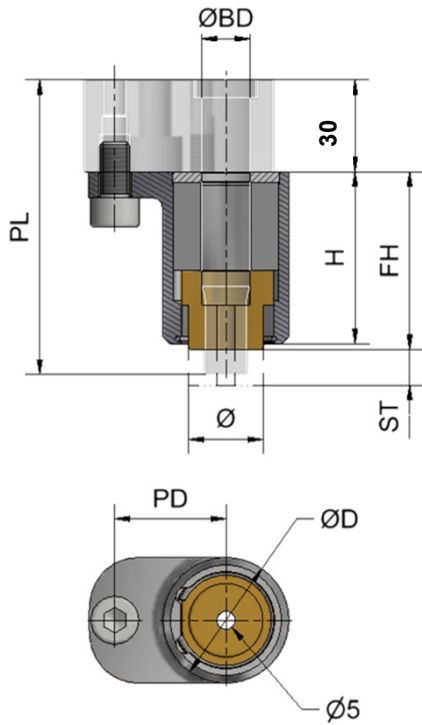

- The stripper with  $\Phi 5$ mm hole

- When ordering with punch and retainer, Delivery with assembled

Series	BD	D	PD	H
ADS-10M	10	30	29	43.5
ADS-10ML				51
ADS-13M	13	34	32	43.5
ADS-13ML				51
ADS-16M	16	43	34	43
ADS-16ML				50.5
ADS-20M	20	50	36	43
ADS-20ML				50.5
ADS-25M	25	60	39	43
ADS-25ML				50.5

Series	Punch Length PL/ Final Height FH			ST.	* Max. Force
	80mm	90mm	100mm		
ADS-10M	45	55	65	6.5	4.4 (455)
ADS-10ML	X	52.5	62.5	9	
ADS-13M	45	55	65	6.5	4.7 (480)
ADS-13ML	X	52.5	62.5	9	
ADS-16M	45	55	65	6.5	5.4 (550)
ADS-16ML	X	52	62	9.5	
ADS-20M	45	55	65	7	6 (620)
ADS-20ML	X	52	62	9.5	
ADS-25M	45	55	65	7	9.7 (990)
ADS-25ML	X	52	62	9.5	

**ORDER**

CODE	PL	Mat'l
ADS-10	80	C
ADS-10M	90	
ADS-10ML	100	

▪ C : Mos2 coated steel stripper / SM45C

- Due to the characteristics of the disc spring stacking structure, the maximum stripping force may vary by approximately 7%
- ADS is compatible with the **25t Dayton standard retainer**. For the **30t Misumi retainer**, refer to **ADS-M**.
- The disk springs are assembled in a non-removable structure to maintain the optimal disc spring stacking configuration.
- When ordered with the punch code, the stripper will be delivered with additional machining work.